



**BOSCH**

# Akumul. uhlová brúska

GWS 18V-15 P | 3 601 JH6 A02

---

## Obsah

Nákres výrobku.....	2
---------------------	---

Nákres výrobku - E

3 601 JH6 A02  
Stand } 22-05-27  
Issue } **Fig./Abb. 1**

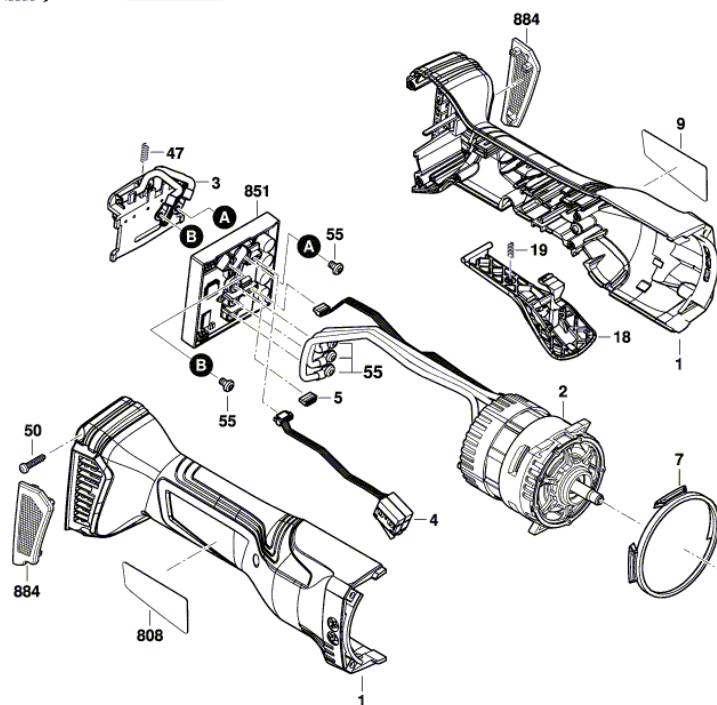

Änderungen vorbehalten  
Modifications reserved  
Modifications réservées  
Salvo modificaciones

● = Zahnspiel 0,08 - 0,25mm mit Pos. 35 eingestellt  
Tooth clearance 0.05 - 0.20mm adjusted with Pos. 35

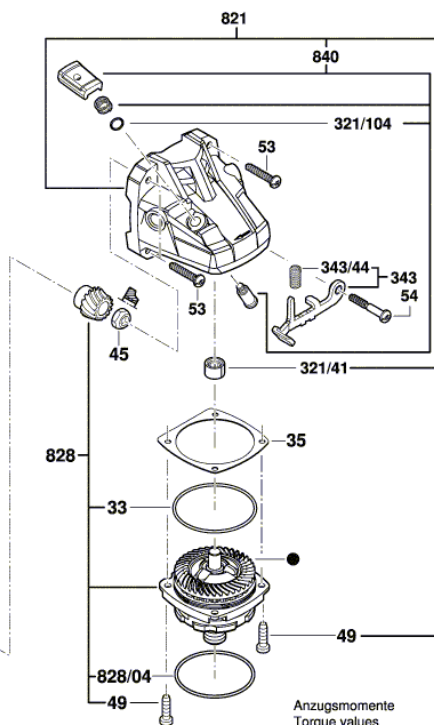

Anzugsmomente  
Torque values  
Couple de serrage  
Pares de apriete  
Pos. 45 = 8,0 - 12 Nm  
Pos. 49 = 2,6 - 3,5 Nm  
Pos. 50 = 0,8 - 1,0 Nm  
Pos. 53 = 1,5 - 1,8 Nm  
Pos. 54 = 1,5 - 1,8 Nm

Nákres výrobku - E

3 601 JH6 A02  
 Stand } 22-05-16 **Fig. /Abb. 2**  
 Issue }

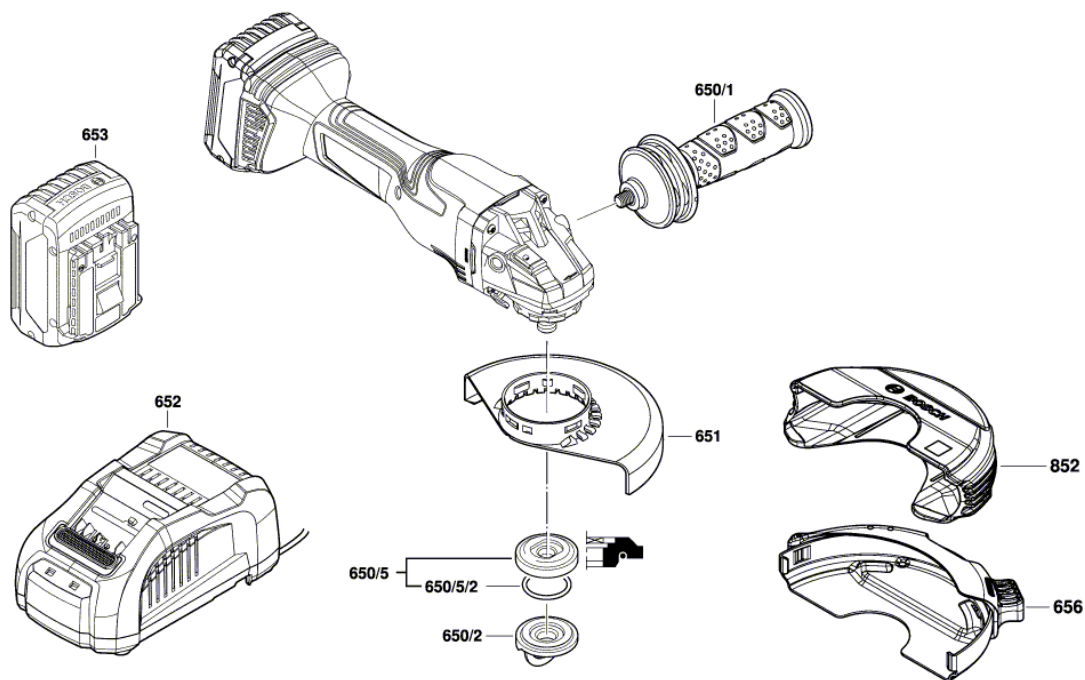

Änderungen vorbehalten  
 Modifications reserved  
 Modifications réservées  
 Salvo modificaciones